

PAINT BORER

518 MC

PAINTXPLORER

548

Thickness measurements
in accordance with
the standardised
wedge cut method



PAINT BORER 518 MC



PAINTXPLORER 548

testing equipment for quality management

ERICHSEN
since 1910

Technical Description

DIN 50 986
ISO 2808
ASTM D 4138
ASTM D 5796

- Thickness measurement of all coatings on any substrate
- Measurement of individual layers of a multi-layer coating

Universal Thickness
Measuring Instruments

Thickness Measuring Instrument PAINT BORER 518 MC



PAINT BORER 518 MC with specimen platform

The Measuring Principle

The **PAINT BORER 518 MC** operates in accordance with the standardised wedge cut method in which the specimen is cut at a defined angle. From the projected width of the cut face the layer thickness can be calculated making use of a simple geometrical relationship. With **Model 518 MC** the damage to the coating is limited to a small conical hole as illustrated in the sectional view. In the measuring microscope a system of concentric circles is visible and from the difference in the radii of the circles which are measured using the measuring microscope, the film thickness can be calculated by multiplying with a known factor.

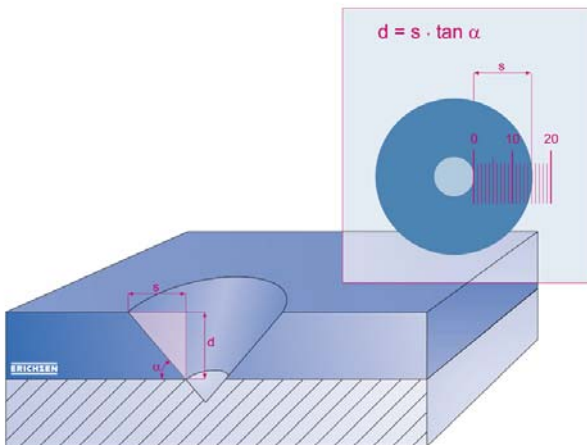

The Measuring Instrument

The **PAINT BORER 518 MC** is a very compact instrument. All the principal components - the drilling device, the measuring microscope, the specimen illumination and the battery - are enclosed in a sturdy housing. A slide moving on horizontal slide-ways houses the drill and microscope and gives the **PAINT BORER 518 MC** its particular feature: the instrument itself does not have to be moved for measuring after drilling.

The drill is spring mounted in the slide so that it can be pressed down onto the specimen with minimum force, the drill being switched on automatically when this is done. The carbide drills are easy to exchange and supplied with different accurately maintained cutting angles for 3 standard measuring ranges. The measuring microscope with a magnification factor of 50 has a measuring scale with 100 lines so that a resolution of 1% is obtained irrespective of the measuring range.

The light button on the backside of the **PAINT BORER 518 MC** can be set for either continuous light as well as three levels of illumination or interrupted illumination to prolong battery life. A 9-volt rechargeable battery is employed; mains operation with the charging unit is possible.

Due to the mobility of the microscope into two directional axes (turned by 90° from one another) and with the possibility of turning the scale, the **PAINT BORER 518 MC** is especially suitable for the evaluation of elliptical holes that arise with curved/tilted specimens.

The Operation

The coating thickness measurement with **PAINT BORER 518 MC** is very simple: Apply a contrast mark (felt tip pen) and place the measuring instrument on the specimen. Move the drill into position over the test point and lower it causing the motor to switch on. Drill the coating through to the substrate. Move the microscope over the hole and switch the lamp on. Count the number of scale marks between the base material and the contrast mark and multiply this value by the scale factor which gives the measuring results.

Special applications (individual layers of a multi-layer system, measurements on curved/tilted specimens) are dealt with in the operating instructions.

Thickness Measuring Instrument PAINTXPLORER 548

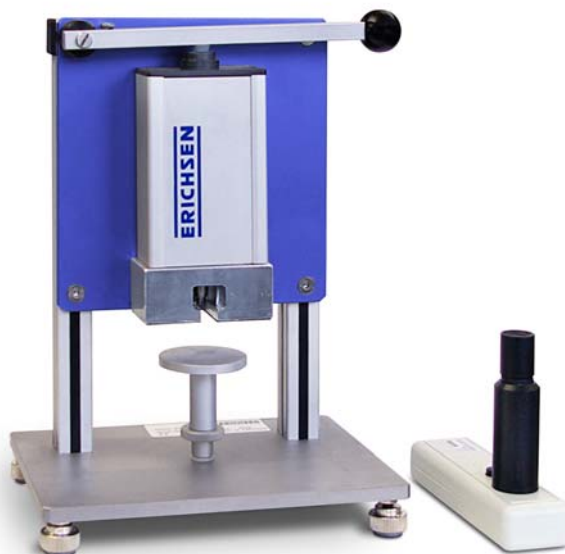

PAINTXPLORER 548 with drilling stand and measuring microscope

The Measuring Principle

The **PAINTXPLORER 548** functions in accordance with the same measuring principle of the standardized wedge cut method as the **PAINT BORER 518 MC**.

The Measuring Instrument

The **PAINTXPLORER 548** has been developed to extend the range of the application of the **PAINT BORER 518 MC**, especially targeting sensitive drillings, particularly into rigid/brittle materials. It is possible that, already at minor eccentric irregular running of the drill used or of its centre axle, such materials can be subject to breaking off of the cutting edges including chipping off, leading afterwards during the optical measurement with the microscope also to limitedly definable transitions between the layers to be measured.

To minimise these limitations the **PAINTXPLORER 548**, a convenient tabletop unit, is equipped with an improved rotating/sliding high precision axle-bearing device. Although the application can be considered as mobile in the range of the length of the mains cable, it is nevertheless the question of a laboratory equipment. It can either be held in hand or used in connection with the measuring stand that is included in the scope of supply.

The appropriate measuring microscope is not integrated in the housing, as for the **PAINT BORER 518 MC**, but is available separately, if required, as a self-contained component (e. g. for the evaluation of damages of lacquers, corrosion creep, pores etc.) which results in the slender handy design of the **PAINTXPLORER 548**.

The Operation

In principle, the **PAINTXPLORER 548** is used in the same way as the **PAINT BORER 518 MC**:

- Application of a contrast mark.
- Placing the instrument onto the specimen, positioning the drill directly above the test point. When using the stand, position the test point on the specimen directly beneath the drill. Then fix the specimen from underneath by rotating the pressure plate.
- Drilling through the layer to the substrate.
- Carrying out the measurement with the help of the microscope considering the scale factor.

The geometry of the specimen admissible for the coating thickness measurement with the **PAINTXPLORER 548** depends on whether the drilling unit is used with or without drilling stand.

Configuration	Geometry of the specimen		
	Length (mm)	Width (mm)	Thickness (mm)
Drilling unit only	min. 40	min. 80	optional
Drilling unit and drilling stand	min. 10	min. 15 max. 110	max. 20

Technical Data (Model 518 MC)

Dimensions (L x W x H): 145 x 55 x 110 mm
 Net weight: approx. 850 g
 Measuring accuracy: 1%

Mains supply (optional):
 Accu 6F 22
 Battery (9V) 6LR 61
 Plug-in power pack (100 - 240) VAC, (47 - 63) Hz
 18 VDC / 0,8 A

Min. dimensions of sample:
without specimen table 150 x 25 mm
with specimen table 10 x 6 mm

Order Informations	
Ord.-No.	Product Description
0283.01.31	PAINT BORER 518 MC
Included in the scope of supply:	
<ul style="list-style-type: none"> ◆ drill no. 5 ◆ 2 felt tip pens (black/silver) ◆ screw driver ◆ rechargeable battery (9 V) ◆ power pack (100 - 240) VAC, (47 - 63) Hz ◆ plastic case ◆ operating instructions 	

Accessories/Spare Parts	
Ord.-No.	Product Description
910927141	Drill No. 1 (up to 2000 µm)
910927241	Drill No. 2 (up to 200 µm)
910927841	Drill No. 3 (up to 1000 µm)
910927741	Drill No. 4 (up to 500 µm)
910928241	Drill No. 5 (up to 300 µm) – Spare part
0870.01.32	Specimen platform for clamping specimen panels of any shape or profile

Technical Data (Model 548)

Drilling Unit
 Dimensions (H x W x D): 145 x 70 x 40 mm
 Net weight: approx. 600 g
 Number of revolutions of the drill: approx. 500 rpm

Mains supply
 Plug-in power pack: (100 - 240) VAC, (47 - 63) Hz
 18 VDC / 0,8 A

Drilling Stand
 Dimensions (H x W x D): 280 x 190 x 120 mm
 Net weight: approx. 3.2 kg

Measuring Microscope (456-50)
 Dimensions (H x W x D): 105 x 130 x 40 mm
 Net weight: approx. 150 g
 Magnification factor: 50
 Measuring range: 2 mm
 Scale division: 20 µm
 Power supply: battery (9V) 6LR 61

Order Informations	
Ord.-No.	Product Description
0280.01.31	PAINTXPLORER 548
Included in the scope of supply:	
<ul style="list-style-type: none"> ◆ drilling stand ◆ drill no.5 ◆ 2 felt tip pens (black/silver) ◆ screw driver ◆ tool for change of drills ◆ power pack (100 - 240) VAC, (47 - 63) Hz ◆ plastic case ◆ operating instructions 	

Accessories/Spare Parts	
Ord.-No.	Product Description
910927141	Drill No. 1 (up to 2000 µm)
910927241	Drill No. 2 (up to 200 µm)
910927841	Drill No. 3 (up to 1000 µm)
910927741	Drill No. 4 (up to 500 µm)
910928241	Drill No. 5 (up to 300 µm) – Spare part
0836.01.32	Measuring microscope 456-50

Drills for Models 518 MC and 548

Drill	No. 2 ¹⁾	No. 5 ²⁾	No. 4 ¹⁾	No. 3 ¹⁾	No. 1 ¹⁾
Measuring range	up to 200 µm	up to 300 µm	up to 500 µm	up to 1000 µm	up to 2000 µm
Scale factor (f)	2 µm/sc.div.	3 µm/sc.div.	5 µm/sc.div.	10 µm/sc.div.	20 µm/sc.div.
Cutting angle (α)	5,7°	8,5°	14,0°	26.7°	45°
tan α	0.10	0.15	0.25	0.50	1.0
Geometry	two-edges				single-edges
Head-Ø	5 mm				
Material	carbide				

The right of technical modifications is reserved.
 Group 10 - TBE 518 MC/548 – VII/2013

