

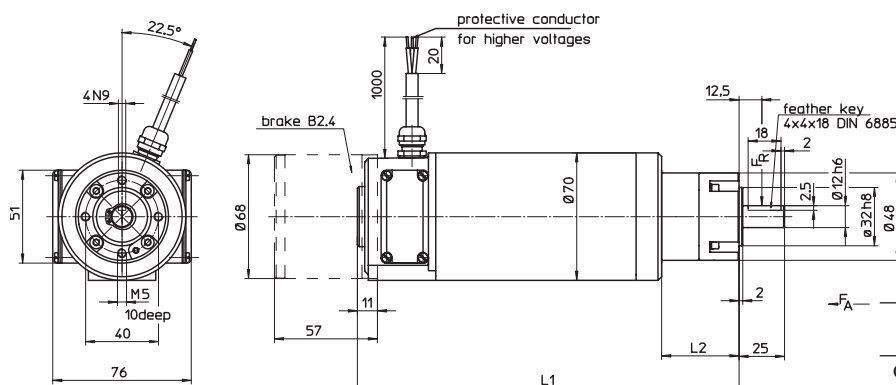

GNM 4175 - GP 48.3

DC
Geared Motors
with permanent magnet field

Motor series GNM 4175
with + without parking brake
Planetary gear series GP 48.3
up to 25 Nm



Type	Gear Ratio	Dimension	
		L1	L2
GNM 4175A	5 : 1 - 7,66:1	211	43
GNM 4175A	21 : 1 - 36 : 1	227,5	59,5

type	GNM 4175 - GP 48.3		
series	A		
operation acc. to standards VDE 0530	S1		
isolation acc. to standards VDE 0530	F		
protection acc. to standards VDE 0530	IP 54		
kind of connection	cable		
rotating direction	reversible		
bearing (motor and gear box)	ball bearing		
gear box	not self-locking		
parking brake B 2.4:			
nominal voltage	V	24	
nominal current	A	0,35	
static break torque	Nm	0,8	
max. number of operations/h		2000	

- Motors also available with DC-tachometer and/ or incremental encoder

Motor design:

Brush holder opening will be accessible by removing the cover plate.

Flange mounting with 4 threads, see drawing.

Rotating direction:

The rotating direction can be changed by inverting the connections.

1. Order example

Motor - gear box
GNM 4175A - GP 48.3
24 V, 3000 rpm - 5:1

2. Order example

Motor - gear box - DC-tachometer
GNM 4175A - GP 48.3 - T 10.05
42 V, 3000 rpm - 21:1 - 5 V / 1000 rpm

Special designs on request.

GNM 4175A - GP 48.3

1 nominal voltage ¹⁾	2 nominal speed	3 nominal torque	4 starting torque	5 nominal torque at undulatory current	6 nominal power	7 nominal current	8 nominal current at undulatory current	9 peak current	10 power gear box input	11 nominal speed gear box input	12 ratio gear box	13 efficiency gear box	load limitations gear box			17 max. backlash	18 moment of inertia gear box ³⁾	19 total weight motor + gear box	20 total weight motor + gear box + parking brake	21 F _r (allow. radial shaft load) ⁴⁾	22 F _a (allow. axial shaft load)
													14 max. power	15 max. cont. torque	16 max. starting torque						
V	rpm	Nm	Nm	Nm	W	A	A	A	W	rpm	i	%	W	Nm	Nm	< min	kgm ²	kg	kg	N	N
24 42 180	600	2,0	8,0 ²⁾	1,3	125	7,5 4,2 1,0	5,3 2,9 0,70	48 ²⁾ 27 ²⁾ 6,2 ²⁾	140	3000	5 :1	90	140	2,2	8,0	40	0,00017x10 ⁻³	3,0	3,4	112	100
24 42 180	500	2,4	8,0 ²⁾	1,6	125	7,5 4,2 1,0	5,3 2,9 0,70	40 ²⁾ 22 ²⁾ 5,2 ²⁾	140	3000	6 :1	90	140	2,7	8,0	40	0,00012x10 ⁻³	3,0	3,4	112	100
24 42 180	392	3,1	8,0 ²⁾	2,0	125	7,5 4,2 1,0	5,3 2,9 0,70	32 ²⁾ 18 ²⁾ 4,1 ²⁾	140	3000	7,66:1	90	140	3,4	8,0	40	0,00007x10 ⁻³	3,0	3,4	112	100
24 180	320	2,2 ²⁾	8,0 ²⁾	1,5	74	4,3 ²⁾ 0,63	3,2 0,44	27 ²⁾ 3,6 ²⁾	82	1600	5 :1	90	74	2,2	8,0	40	0,00017x10 ⁻³	3,0	3,4	112	100
24 180	267	2,7	8,0 ²⁾	1,8	76	4,5 0,63	3,2 0,44	22 ²⁾ 3,0 ²⁾	84	1600	6 :1	90	75	2,7	8,0	40	0,00012x10 ⁻³	3,0	3,4	112	100
24 180	209	3,4 ²⁾	8,0 ²⁾	2,3	74	4,4 ²⁾ 0,60 ²⁾	3,2 0,44	17 ²⁾ 2,4 ²⁾	82	1600	7,66:1	90	74	3,4	8,0	40	0,00007x10 ⁻³	3,0	3,4	112	100
24 42 180	143	8,0	22 ²⁾	5,2	120	7,5 4,2 1,0	5,3 2,9 0,70	32 ²⁾ 18 ²⁾ 4,1 ²⁾	140	3000	21 :1	85	140	9,5	22	45	0,00015x10 ⁻³	3,2	3,6	150	110
24 42 180	100	11	25 ²⁾	7,5	120	7,5 4,2 1,0	5,3 2,9 0,70	26 ²⁾ 14 ²⁾ 3,3 ²⁾	140	3000	30 :1	85	140	13,5	25	45	0,00010x10 ⁻³	3,2	3,6	150	110
24 42 180	83	14	25 ²⁾	9,0	120	7,5 4,2 1,0	5,3 2,9 0,70	22 ²⁾ 12 ²⁾ 2,8 ²⁾	140	3000	36 :1	85	145	16,5	25	45	0,00010x10 ⁻³	3,2	3,6	150	110
24 180	53	13	25 ²⁾	8,7	72	4,5 0,63	3,2 0,44	14 ²⁾ 1,9 ²⁾	85	1600	30 :1	85	75	13,5	25	45	0,00010x10 ⁻³	3,2	3,6	150	110
24 180	44	16	25 ²⁾	10	72	4,5 0,63	3,2 0,44	12 ²⁾ 1,6 ²⁾	85	1600	36 :1	85	77	16,5	25	45	0,00010x10 ⁻³	3,2	3,6	150	110

Tolerances ± 10 %

Columns 3 and 13

Values are valid at operating temperature after run-in period.

Columns 5 and 8

Current values should not exceeded during operation with undulatory current (single way rectification) with harmonic portion above 5%.

Columns 4 and 9

Figures correspond with the gearbox load limitations. For high gear ratios the allowed currents may be lower than the motors rated current. If so, please the current has to be limited, e.g. through adjusting the servo controller.

Columns 14, 15 and 16

To avoid gear box overload do not exceed the mentioned values. For oscillating operation the mentioned limitations must be multiplied by 0,75.

¹⁾ 180V - special voltage

²⁾ motor current must be limited to avoid excess of the mentioned value

³⁾ values are reduced to motor shaft

⁴⁾ middle of the shaft-extension